

Agma22 - Compact Float Switch System

An enclosed and compact float switch for direct mounting on a de-watering pump

- For use with Submersible Drainage Pumps
- Provides Automatic Operation in Tight Spaces Where a Float Switch Cannot be Relied Upon
- Directly Control Pumps up to 8A
- Magnetically Assisted Float System
- Patented Magnetic Operation
- Ideal for Pumps Deployed in Small Sumps or Flood Drainage Crates
- IP68 Fully Waterproof

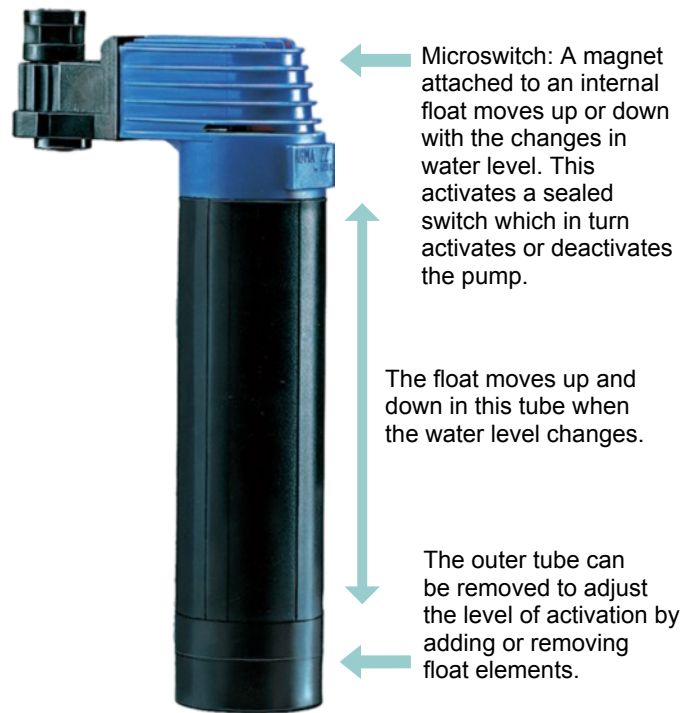

How Does It Work?

Mac3 **Agma22** is a compact float switch alternative, designed to be fitted to a submersible pump. When used for pump control, **Agma22** activates a connected pump when the water levels are high enough for pump use, and deactivates the pump when the water level has decreased to the set minimum.

Agma22 is mounted vertically, attaching to the pump cable entry, allowing it to be used in areas where a lack of space would prevent a conventional float switch from being used.

Typical uses include pumps designed for:

- Flood prevention sumps
- Small water tanks
- Narrow wells
- Irregular shaped tanks
- Tanks, sumps or wells with pipes or other obstructions inside

Agma22 is designed to be used with clean water or water with a very low solid content. Not suitable for slurry or foul water applications. Avoid using in water containing iron or other ferrous materials as these may affect operation.

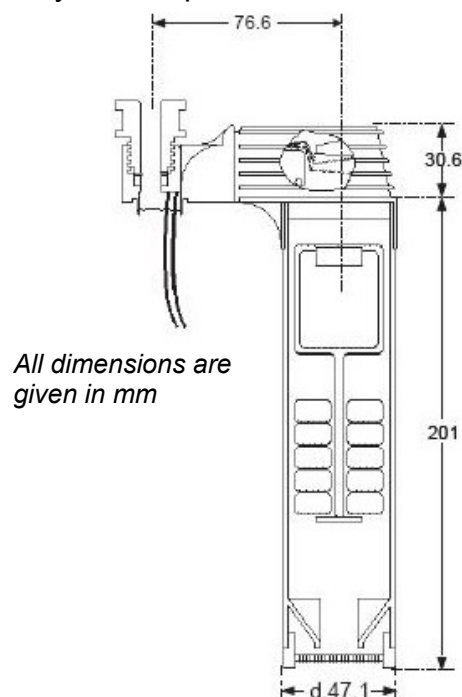

Agma22 - Compact Float Switch System

An enclosed and compact float switch for direct mounting on a de-watering pump

Technical Specifications

Physical	Model A	Model B
Material - Body	Non-toxic Polypropylene	
Weight	300g	
Dimensions	37 x 100 x 226.5 mm	
Working Position	Vertical $\pm 5^\circ$ Max	
Electrical		
Max Load	20(8)A 250V~ Single Phase	
Maximum Operating Pressure	0.5 Bar	
Working Liquid	Clean Water	
Operating Range (Level)	7 - 8 cm	
Operating Temperature	0°C to +50°C	
Storage Temperature	-10°C - +60°C	
Cable Type*	2 PVC Flame Retardant Cable 3 PVC Flame Retardant Cable	H07RN-F 3G1 H07RN-F 2X1
Ingress Protection Rating	IP68	
Compliance Certification	CE	CE EN60730

* Model A is supplied with 25cm of cable. Model B is supplied with 50cm of cable.

3P Technik UK Limited
Unit 9 Parc Teifi
Cardigan
SA43 1EW

Phone : 01239 623506
Fax : 0845 544 3150

sales@3ptechnik.co.uk

www.3ptechnik.co.uk
www.mac3uk.com

